

JCM Weld On Tapping Outlets

Weld-on outlets & connections are dependable and economical with JCM Weld On Fittings

Outlets, partial sleeves and complete sleeves are readily available for steel pipe 6" and larger with size on size and reducing outlets. Outlets and partial sleeves are also available for tank and bulkhead use. Various configurations of this design are available. Featured below are the most popular.

MATERIAL SPECIFICATIONS

BODY: ASTM 283, 285 Grade C, ASTM A-36 Steel or equal. Optional 304 or 316 Stainless Steel.

FINISH: Heavy coat of corrosion resistant metal primer. Optional Fusion Epoxy Coating available.

FLANGE: AWWA C207 Class D, ANSI 150 drilling recessed for tapping valve per MSS-SP60. Other flanges available.

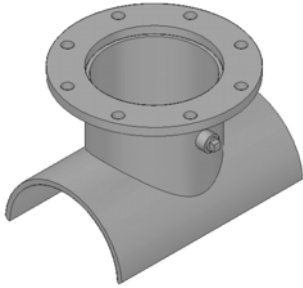

**416 Type 1:
Weld On Outlet**

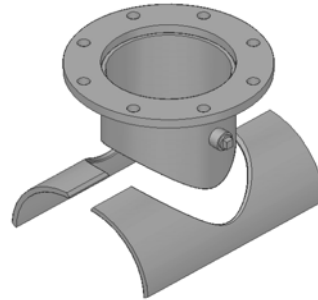

**416 Type 2:
Split Tee
Three Piece Weld On Saddle**

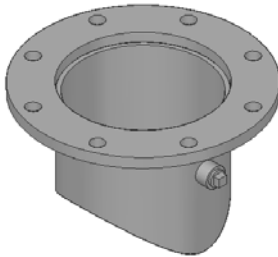

**416 Type 3:
Flanged Nozzle
Weld On Outlet**

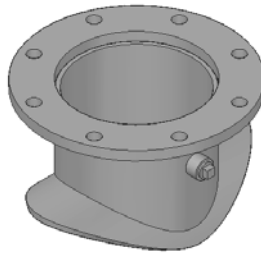

**416 Type 4:
Hat Flange Weld On
Outlet**

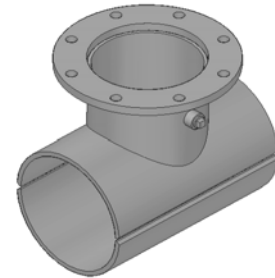

**417 Type 1:
Split Tee
Weld On Tapping Sleeve**

Other configurations
available upon
request.

HOW TO ORDER - JCM WELD ON OUTLETS

1. Determine pipe O.D. and outlet size. Each sleeve is fabricated to the exact O.D. of the pipe.
2. Determine sleeve type required.

For Standard Type 1 416 Weld On Outlet for steel pipe with 6.63 O.D. with 6" outlet, order: 476-0663 x 6 Type1.

Other configurations and designs available.

Standard outlet flange is AWWA C207 Class D, ANSI 150lb Drilling, recessed for tapping valve MSS-SP60. Other flanges available upon request.

